

GESTRA Steam Systems

Product Range A3

Continuous Blowdown Valves

Reactomats

BA 28, BA 29, BA 210, BA 211

PN 63 – 320, DN 25 mm (1")

BA 28

BA 29

BA 210

BA 211

Description

The valve is connected to the water space of the boiler. Precise adjustment of blowdown rate by turning regulating lever on the calibrated scale plate (see charts on back page).

With the regulating lever in blow-off position the capacity is approximately three times the capacity at scale division 100.

The BA includes a sampling valve for checking the boiler-water concentration.

Application

Continuous blowdown of steam boilers, evaporators, Quench coolers and similar installations. Regulating or dosing valve for all industries.

Connections

Butt-weld ends for pipe according to DIN 2448:

30 x 2.6 to 4.5

31.8 x 2.6 to 5

33.7 x 3.6 to 6.3

38 x 5.6 to 8

ANSI B 36.10: 1" Schedule 80 and 160

Other dimensions or weld-neck flanges on request at extra cost.

Design

Straight-through valves with butt-weld ends, weld-neck flanges at extra cost. With GESTRA stage-nozzle, regulating lever, calibrated scale and sampling valve.

On request with electric actuator as BAE 28 – 211.



BA 28 – BA 211

Range

If used as continuous blowdown valve (at saturation temperature):

BA 28 max. 63 bar g (915 psig)

BA 29 max. 94 bar g (1360 psig)

BA 210 max. 142 bar g (2060 psig)

BA 211 max. 226 bar g (3280 psig)

Max. temperature		°C	120	200	250	300	350	400	450	500	530
Max. service pressure	BA 28 PN 63/100	barg	100	80	70	60	56	50	–	–	–
		psig	1450	1160	1015	870	810	725	–	–	–
	BA 29 PN 160*)	barg	160	130	112	96	90	80	–	–	–
		psig	2320	1885	1625	1390	1305	1160	–	–	–
BA 210 PN 250*)	barg	250	200	175	150	140	125	–	–	–	
	psig	3625	2900	2540	2175	2030	1810	–	–	–	
BA 211 PN 320*)	barg	320	320	320	320	304	292	278	237	124	
	psig	4640	4640	4640	4640	4410	4235	4030	3435	1800	

*) For relatively small capacities (see charts) use BA 29k, 210k or 211k with special stage nozzle.

Materials

BA 28

Body (two parts): forged steel C 22.8 (No. 1.0460 DIN)

Nozzle insert: cast stainless steel G-X 22 CrMoV 12 1 (1.4931)

Stage nozzle: stainless steel C 20 Cr 13 (1.4021)

BA 29

Body (two parts): C 22.8 (1.0460)

Nozzle insert*): G-X 22 CrMoV 12 1 (1.4931)

Stage nozzle*): stainless steel X 8 CrTi 17 (1.4510)

BA 210

Lower-body part: C 22.8 (1.0460)

Upper-body part*): C 22.8 (1.0460)

Nozzle insert*): G-X 22 CrMoV 12 1 (1.4931)

Stage nozzle*): X 8 CrTi 17 (1.4510)

BA 211

Lower-body part: forged alloy steel 13 CrMo 44 (1.7335)

Upper-body part*): 13 CrMo 44 (1.7335)

Nozzle insert*): G-X 22 CrMoV 12 1 (1.4931)

Stage nozzle*): X 8 CrTi 17 (1.4510)

*) additionally armoured

Order Specifications

Valve type, nominal pressure (PN), nominal size (DN), capacity, service pressure, back pressure, fluid, application (e.g. type of boiler).

The following test certificates can be issued on request, at extra cost:

In accordance with EN 10204-2.1, -2.2, -3.1A, -3.1B and -3.1C.

All inspection requirements have to be stated with the order. After supply of the equipment certification cannot be established. For tests and inspection charges please consult us.

Enquiry Specification

Reactomats (continuous blowdown valves) with GESTRA stage nozzle, regulating lever, calibrated scale and sampling valve.

Application (optional) as continuous blowdown valve for steam boilers, evaporators and similar installations or as regulating/dosing valve.

Indications on nominal pressure (PN), nominal size (DN), type of connection, service pressure, back pressure, temperature, fluid, application (e.g. type of boiler).

Continuous Blowdown Valves
Reactomats
BA 28, BA 29, BA 210, BA 211
PN 63 – 320, DN 25 mm (1")

Dimensions

BA 28 – 211 (approx. weight 21 kg)

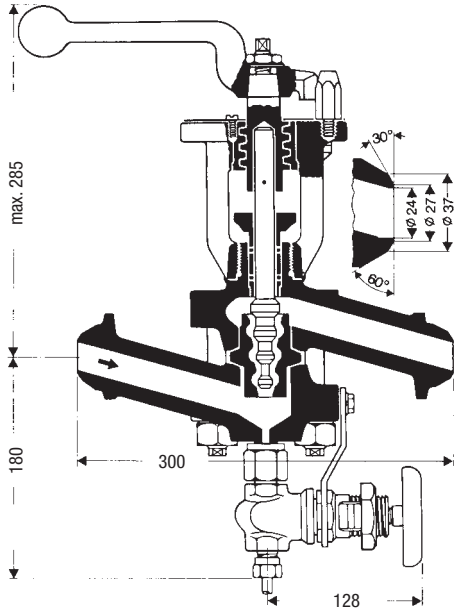

Sampling valve with compression fitting 8 mm O.D.

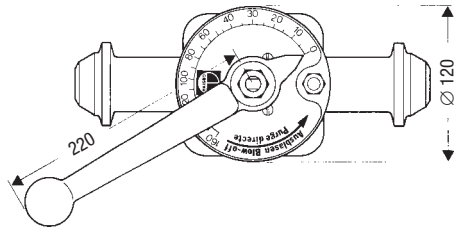

Types, Capacity, Scale Division

Selection of valve type according to pressure and temperature see under "Range".

Scale divisions for required capacity (blow-down quantity) see charts.

In blow-off position (regulating lever against stop) the capacity is approximately three times the capacity at scale division 100.

Chart 1: BA 28, 29, 210, 211

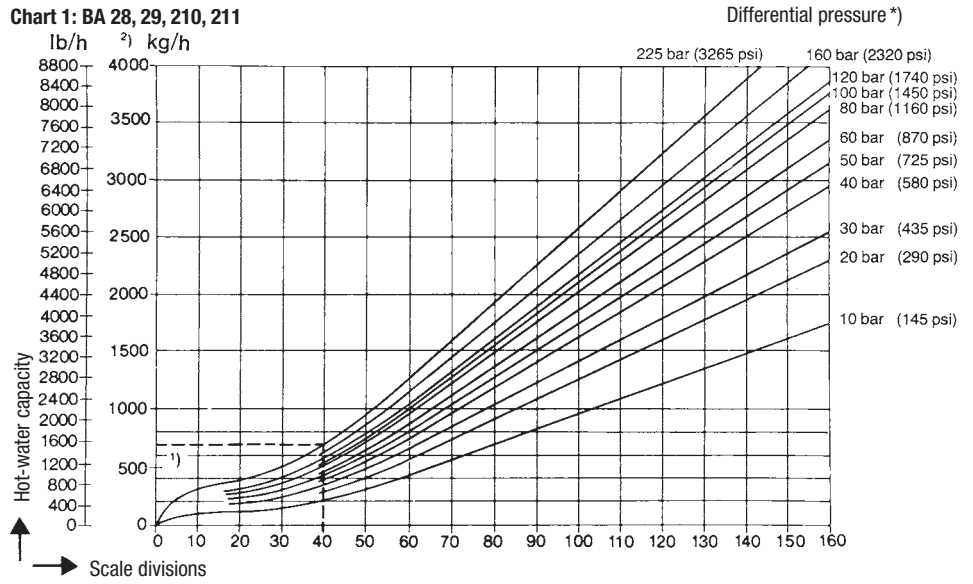

- 1) For relatively small quantities (see dotted lines in chart) use BA 29k, 210k or 211k (with special stage nozzle). Scale divisions according to chart 2.
- 2) If the quantity of boiler water to be discharged is higher than the values covered by chart 1, GESTRA Reactomats BA 39 with radial stage nozzle should be used.

Chart 2: BA 29k, 210k, 211k

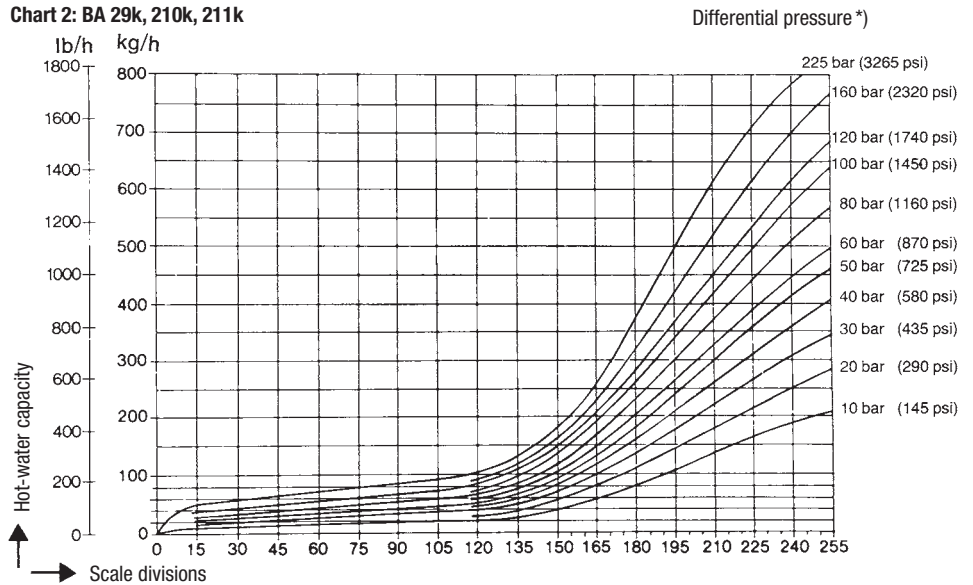

*) Differential pressure (working pressure) = Inlet minus outlet pressure.

If the boiler water is lifted after the Reactomat, the differential pressure is reduced by approximately 1 bar for 7 m (or 2 psi for 3 feet) in lift.

Supply in accordance with our general terms of business.

GESTRA AG

P. O. Box 10 54 60, D-28054 Bremen
 Münchener Str. 77, D-28215 Bremen
 Telephone +49 (0) 421 35 03 - 0, Fax +49 (0) 421 35 03-393
 E-Mail gestra.ag@flowserve.com, Internet www.gestra.de



GESTRA