

GESTRA Steam Systems

Pump Trap UNA 25-PK, PN 40, DN 40

Product Range A1

UNA 25-PK

Description

Ball-float operated steam trap with pumping function. The equipment works primarily as a steam trap. This motive-steam powered pump trap lifts and discharges condensate, even if steam pressure is low or backpressures is high.

The control mechanism consists of a control unit with ball float and rolling ball valve, an orifice, a changeover linkage and a valve block for controlling the motive steam inlet and the vent outlet. The equipment features integrated inlet and outlet check valves, a connection for motive steam and a connection for the vent valve.

Function

The condensate flows through the integrated check valve into the trap body. The float operates the rolling ball valve as a function of the condensate level inside the trap body, thereby opening or closing the orifice. If the differential pressure is sufficiently high, the condensate will be discharged through the orifice and the check valve. The equipment works as a normal steam trap. If, however, the differential pressure is not sufficiently high, the condensate level inside the trap body will continue to rise. When the float reaches its upper tripping point, it will switch the valve block. In this valve block the vent valve will be closed and the motive steam valve opened. The pressure now supplied by the motive steam forces the condensate out of the trap body. When the lower tripping point is reached, the position of the float will cause the valve block to open the vent valve and close the motive steam valve. Condensate flows again through the check valve into the trap body, and a new discharge cycle begins for the pump trap. During the pumping process condensate collects in the supply line of the pump trap.

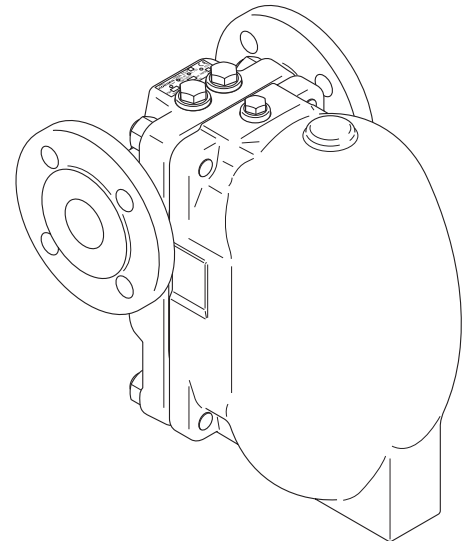

UNA 25-PK

Pressure /Temperature Ratings & End Connections

Flanged PN 40, EN 1092-2, DN 40					
PMA (admissible service pressure)	[barg]	40.0	38.3	31.6	25.0
TMA (admissible service temperature)	[°C]	20	120	250	350
PMO (max. operating pressure)	[bar]	6			
PMOB (max. operating back pressure)	[bar]	3			

Flanged Class 150, ASME B16.5, DN 40					
PMA (admissible service pressure)	[barg]	17.2	13.9	12.1	6.6
TMA (admissible service temperature)	[°C]	20	200	250	350
PMO (max. operating pressure)	[bar]	6			
PMOB (max. operating back pressure)	[bar]	3			

Screwed sockets to EN ISO 228-1, 1½"					
PMA (admissible service pressure)	[barg]	40.0	38.3	31.6	25.0
TMA (admissible service temperature)	[°C]	20	120	250	350
PMO (max. operating pressure)	[bar]	6			
PMOB (max. operating back pressure)	[bar]	3			

Screwed sockets NPT, ASME B1.20.1, 1½"					
PMA (admissible service pressure)	[barg]	40.0	38.3	31.6	25.0
TMA (admissible service temperature)	[°C]	20	120	250	350
PMO (max. operating pressure)	[bar]	6			
PMOB (max. operating back pressure)	[bar]	3			

Materials

Type	UNA 25-PK	
Designation	DIN / EN	ASTM ^{*)}
Body	EN-JS 1049	A 395
Cover	EN-JS 1049	A 395
Internals	Stainless steel	Stainless Steel

^{*)} Physical and chemical properties comply with DIN grade. ASTM nearest equivalent grade is stated for guidance only

Dimensions

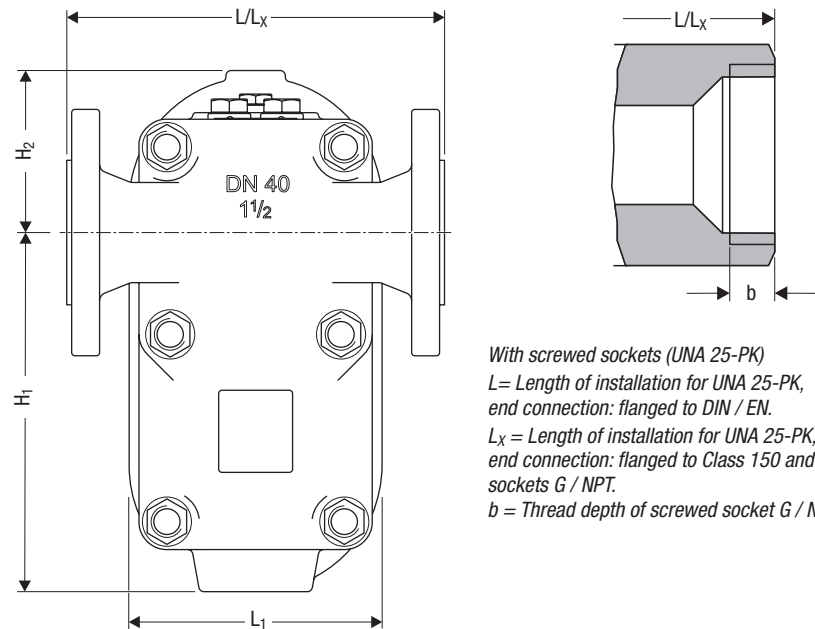
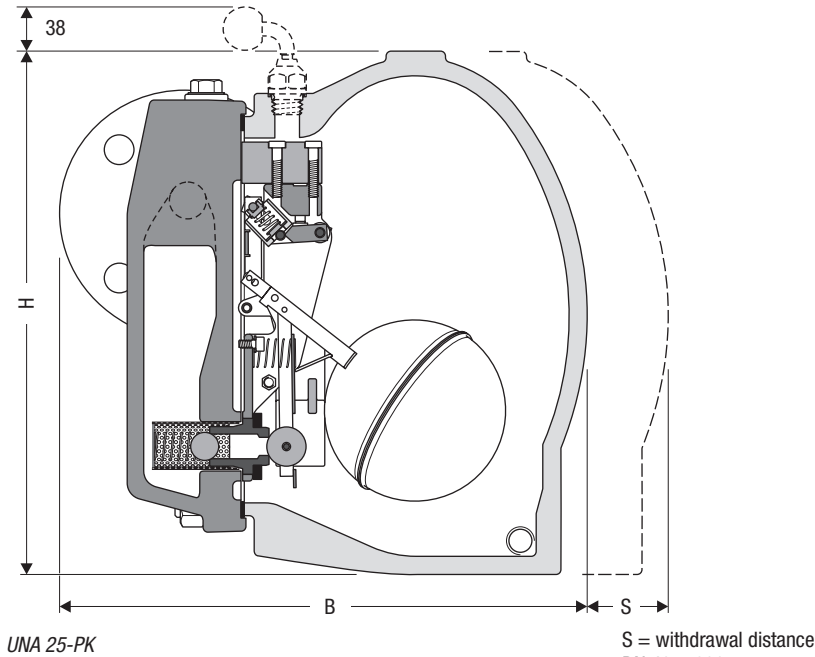

With flanged connection (UNA 25-PK)

L = Length of installation for UNA 25-PK, end connection: flanged to DIN / EN.

L_x = Length of installation for UNA 25-PK, end connection: flanged to Class 150 and screwed sockets G / NPT.

With screwed sockets (UNA 25-PK)

L = Length of installation for UNA 25-PK, end connection: flanged to DIN / EN.

L_x = Length of installation for UNA 25-PK, end connection: flanged to Class 150 and screwed sockets G / NPT.

b = Thread depth of screwed socket G / NPT.

Orifice

Orifice (O) DN 40	K _{VS} value [m ³ /h]	∅ of hole [mm]
Orifice 6	3.5	11.0

The K_V value is the metric measure for the volume flow of water at a temperature of 5 to 30 °C in [m³/h] with a pressure drop across the valve of 1 bar and the respective opening angle of the orifice (O). The K_{VS} value is the K_V value when the orifice (O) is completely open.

See flowrates and capacity charts on page 4.

Dimensions – continued –

DN	[mm]	15	20	25	40	50
	[inch]	½	¾	1	1½	2
UNA 25-PK	L				230	
	L _x				226	
	L ₁				154	
	B				325	
	H				318	
	H ₁				219	
	H ₂				99	
	b (G)				21.4	
	b (NPT)				17.3	

L = Length of installation for UNA 25-PK, end connection: flanged to DIN / EN.

L_x = Length of installation for UNA 25-PK, end connection: flanged to Class 150 and screwed sockets G / NPT.

b = Thread depth of screwed socket G / NPT.

Weights

UNA 25-PK		DN					
End connection	[mm]	15	20	25	40	50	
	[inch]	½	¾	1	1½	2	
Flanged	[kg]				31		
Screwed sockets	[kg]				26		

Componen Parts of UNA 25-PK

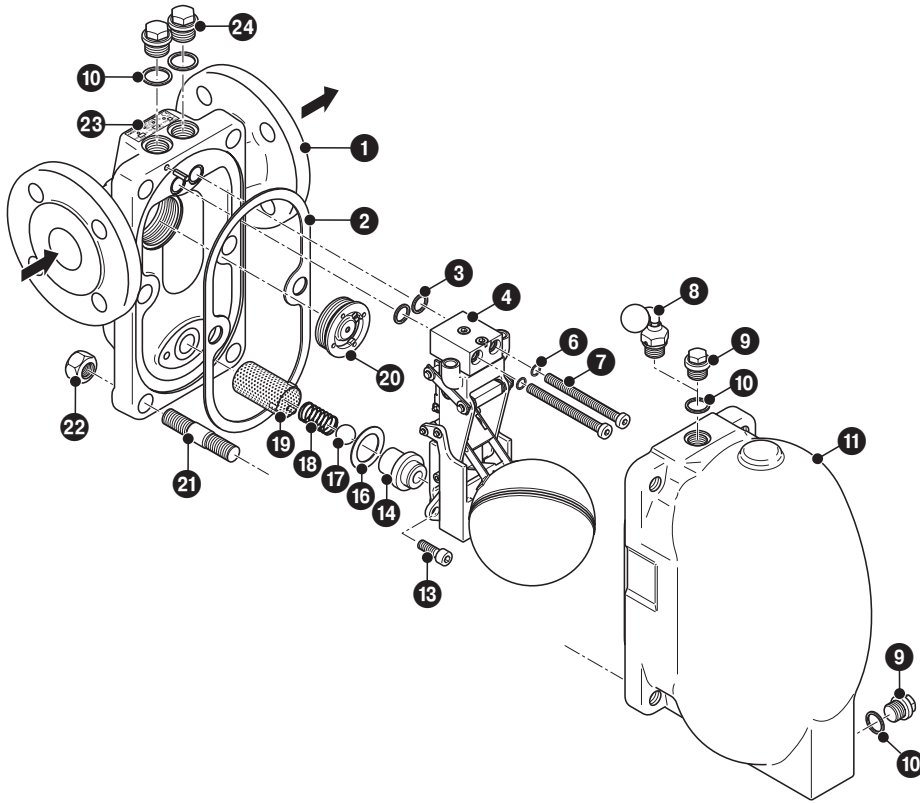

Installation

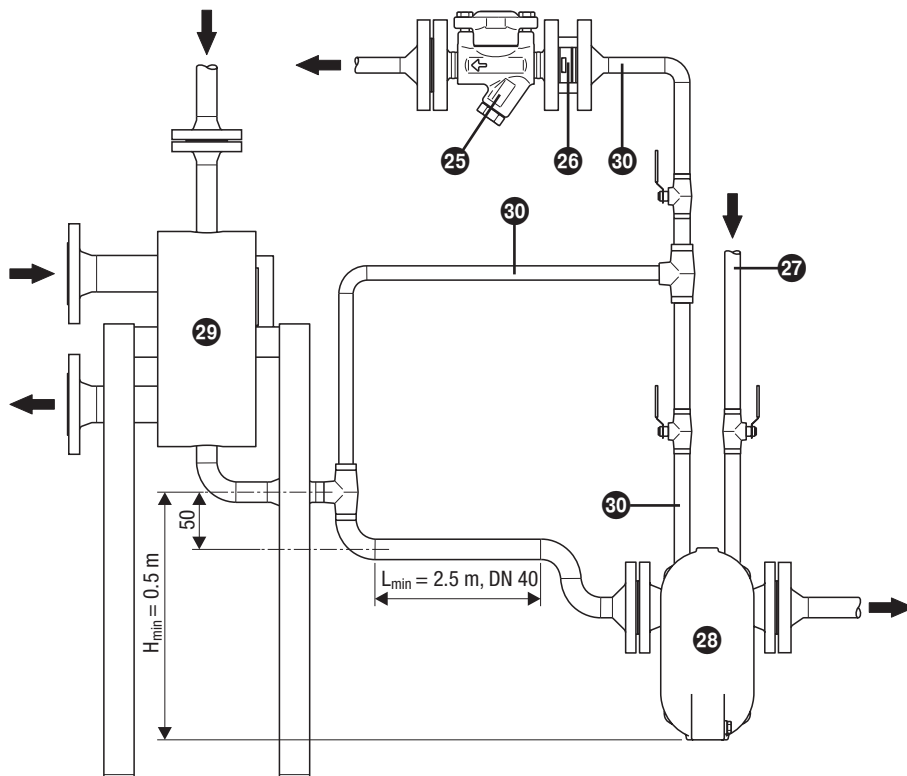

Connection of UNA 25-PK to a heat exchanger

Key

- 1 Body
- 2 Body gasket (graphite/CrNi)
- 3 Gasket
- 4 Control unit UNA 25-PK
- 5 Control unit UNA 25-PS
- 6 Gasket
- 7 Socket-head cap screw
- 8 Hand vent valve
- 9 Sealing plug
- 10 Gasket
- 11 Cover
- 12 Deflection block
- 13 Socket-head cap screw
- 14 Seat (orifice)
- 15 Seat (condensate lifter)
- 16 Seat gasket
- 17 Ball (outlet check valve)
- 18 Spring (outlet check valve)
- 19 Wear protection
- 20 Inlet check valve
- 21 Stud bolt
- 22 Hexagon nut
- 23 Name plate
- 24 Sealing plug
- 25 Thermostatic steam trap, e. g. MK... for deaeration. (Alternatively mounted to vent hole 9 (3/8") of UNA 25-PK)
- 26 Check valve (optional), prevents air from entering the equipment if there is a vacuum.
- 27 Motive steam, drained, DN 15 (1/2").
- 28 UNA 25-PK
- 29 Heat exchanger
- 30 Vent line, DN 15 (1/2")

Please note:

A motive steam line must be connected via female thread 1/2".

The max. motive steam pressure is 6 barg.

A balance line must be connected via female thread 1/2".

There must be a minimum supply head of 0.5 m between the heat exchanger and the UNA 25-PK.

The supply line must be at least 2.5 m long in order to ensure enough buffer volume. Alternatively a buffer reservoir with a volume of 3 litres can be used.

Pump Trap UNA 25-PK, PN 40, DN 40

Flow Characteristics

The tables indicate the max. flowrates of hot condensate and cold water for steam trapping and pumping mode.

The capacities are dependent on the differential pressure (working pressure). The differential pressure is the difference between inlet and outlet pressure and depends among other things on the run of the condensate line. If the condensate downstream of the trap is lifted, the differential pressure is reduced by approximately 1 bar for 7 m lift.

The maximum admissible differential pressure is dependent on the cross-sectional area of the orifice and the density of the liquid.

Inspection & Certification

Documentation regarding material tests and in-house examination with test report EN10204-2.2 available at extra cost. All inspection requirements have to be stated with the enquiry or order. After supply of the equipment certification cannot be established. Charges and extent of the above mentioned test certificates as well as the different tests confirmed therein are listed in our Price List "Test and Inspection Charges for Standard Equipment". For other tests and inspections than those listed above, please consult us.

PED (Pressure Equipment Directive)

The equipment fulfills the requirements of the Pressure Equipment Directive PED 97/23/EC.

For use with fluids of group 2.

With CE marking (apart from equipment that is excluded from the scope of the PED as specified in section 3.3).

ATEX (Atmosphère Explosible)

The equipment does not have its own potential source of ignition and is therefore not subject to the ATEX Directive 94/9/EC. Applicable in Ex zones (surrounding atmosphere) 0, 1, 2, 20, 21, 22 (1999/92/EC). The equipment is not Ex marked.

Supply in accordance with our general terms of business.

Flowrate (trapping mode)

Condensate (hot water)		
Flowrate	[kg/h]	2000
ΔPMX (max. differential pressure)	[bar]	6

Cold water		
Flowrate	[kg/h]	2500
ΔPMX (max. differential pressure)	[bar]	6

Flowrate (pumping mode)

Condensate (hot water) Flowrate at 6 bar motive steam pressure and 1 m supply head		
Flowrate	[kg/h]	460
PMOB (max. operating back pressure)	[bar]	1

Flowrate at 6 bar motive steam pressure and 1 m supply head

Cold water Flowrate at 6 bar motive steam pressure and 1 m supply head		
Flowrate	[kg/h]	610
PMOB (max. operating back pressure)	[bar]	1

Spare parts list for UNA 25-PK

Item	Designation	Stock code
		DN 40
<p>2 3 4 6 7</p> <p>13 16</p>	Control unit UNA 25-PK, screws, gaskets, seat gasket, body gasket	560593
<p>2 3 6 7 13</p> <p>16 20</p>	Inlet check valve, screws, gaskets, seat gasket, body gasket	560595
<p>2 3 6 7 13</p> <p>14 16 17 18</p>	Outlet check valve (cpl.), seat (orifice), screws, gaskets, seat gasket, body gasket	560597

GESTRA AG

P. O. Box 10 54 60, D-28054 Bremen

Münchener Str. 77, D-28215 Bremen

Telephone 0049 (0) 421 35 03 - 0, Fax 0049 (0) 421 35 03-393

E-mail gestra.gmbh@flowserve.com, Internet www.gestra.de

